

# Damage-Risk Criteria: Relationships and Knowledge Gaps

Gregory A. Flamme

William J. Murphy

*DoD Blast Injury Research Coordinating Office Auditory Blast Injury Consensus-Building Meeting  
Maclean, VA, August 2022*

**SASRAC**  
**Stephenson and Stephenson**  
**Research and Consulting**

# Introduction

- The methods used to estimate auditory hazard...
  - ...are based on scant prospective data
  - ...disagree widely on the severity of the hazard
  - ...agree more strongly on the rank-order of hazard, and
  - ...average agreement and disagreement among DRCs is small compared to the range of unexplained inter-subject differences. (Better understanding is important.)
- Only Temporary Threshold Shift (TTS) has been used an outcome in DRC development, which doesn't include:
  - Bothersome/Persistent Tinnitus
  - Cochlear synaptopathy
  - Blast-related TBI
  - Permanent threshold shift

# Damage-Risk Criteria

| DRC                     | Features  |
|-------------------------|---|
| HEL S-1-63B (1965)      | Peak, envelope duration, pressure-wave duration   |
| CHABA (1968)            | Peak, envelope duration, Middle ear muscle contractions   |
| MIL-STD-1474 A/D (1974) | CHABA + Hearing protector (-29 dB peak reduction)   |
| Pfander (1975)          | Peak, envelope duration   |
| Smootenburg (1982)      | Peak, envelope duration   |
| LAeq (1983)             | Integrated A-weighted energy  |
| AHAAH (1991)            | Waveform fine structure, middle ear muscle contractions, stapes limiting, basilar membrane deflection, option in MIL-STD-1474E (2015) |
| LIAeq (2015)            | Integrated A-weighted energy, adjustment for long pressure-wave duration, option in MIL-STD-1474E (2015)                              |
| ICE (2016)              | Modified AHAAH, corrected errors, total energy entering cochlea   |
| Kurtosis-adjusted LAeq  | Integrated A-weighted energy, adjustment for temporal envelope variability  |

# Damage-Risk Criteria

| DRC                     | Features  |
|-------------------------|---|
| HEL S-1-63B (1965)      | Peak, envelope duration, pressure-wave duration   |
| CHABA (1968)            | Peak, envelope duration, Middle ear muscle contractions   |
| MIL-STD-1474 A/D (1974) | CHABA + Hearing protector (-29 dB peak reduction)   |
| Pfander (1975)          | Peak, envelope duration   |
| Smootenburg (1982)      | Peak, envelope duration   |
| LAeq (1983)             | Integrated A-weighted energy  |
| AHAAH (1991)            | Waveform fine structure, middle ear muscle contractions, stapes limiting, basilar membrane deflection, option in MIL-STD-1474E (2015) |
| LIAeq (2015)            | Integrated A-weighted energy, adjustment for long pressure-wave duration, option in MIL-STD-1474E (2015)                              |
| ICE (2016)              | Modified AHAAH, corrected errors, total energy entering cochlea   |
| Kurtosis-adjusted LAeq  | Integrated A-weighted energy, adjustment for temporal envelope variability  |

# A Bird's Eye View of 4800 Impulses

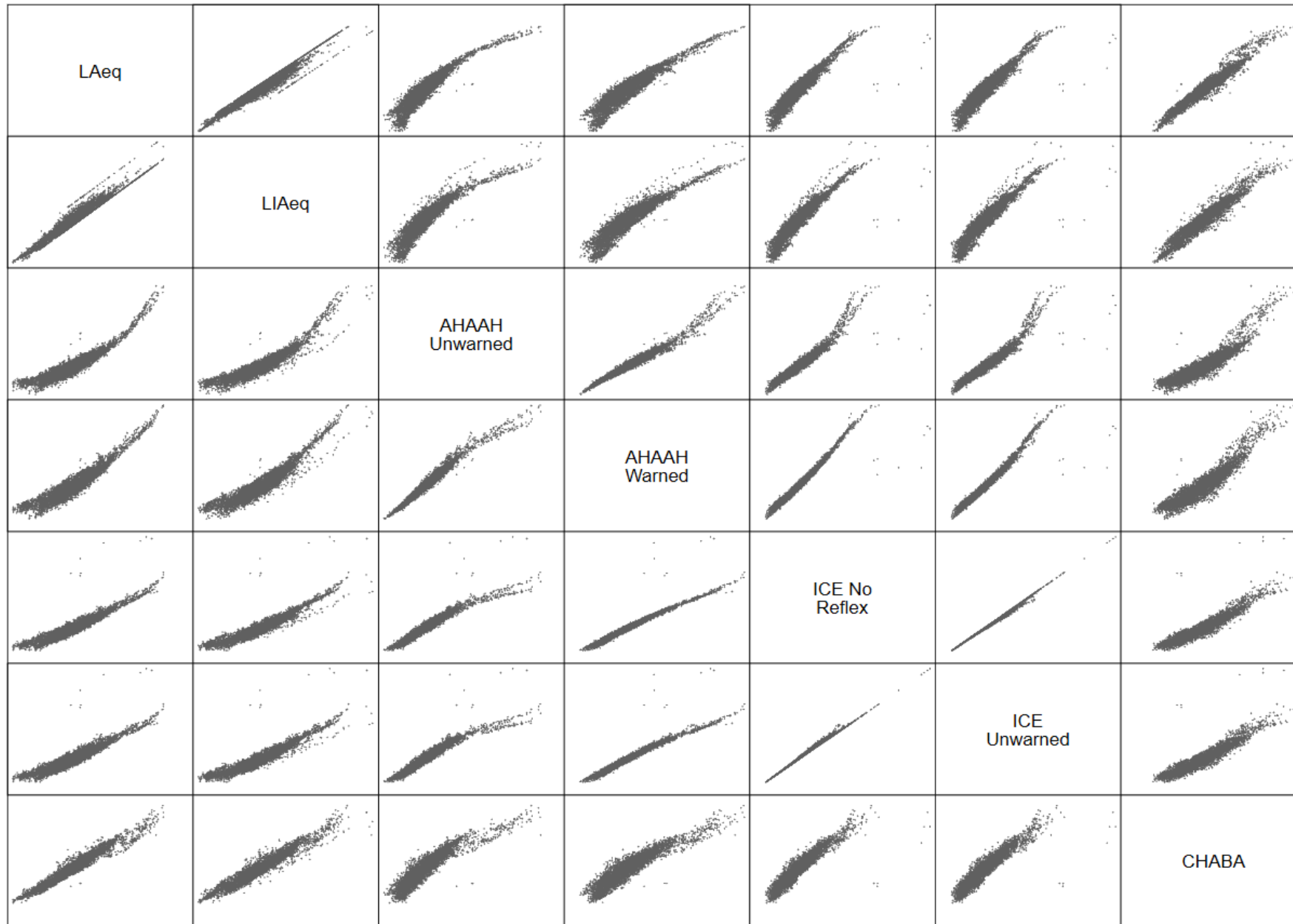

# Regression Predictions

$$\log_{10}(LAeqMPE) = Const + (coef_1 * \log_{10}(CHABA_{MPE})) + (coef_2 * \log_{10}(CHABA_{MPE}^2))$$
$$L_{A,eq,MPE} = 10^{\log_{10}(LAeqMPE)}$$

## Multiple regression

- DV: Log MPE on new DRC
- IV<sub>1</sub>: Log MPE on old DRC
- IV<sub>2</sub>: Squared Log MPE on old DRC
- Constant: difference in permissible exposures if the IV considers 1 shot permissible

| Log (Outcome) | Const | Coef1 | Coef2      | R <sup>2</sup> | IQR low | IQR high | Std Error |
|---------------|-------|-------|------------|----------------|---------|----------|-----------|
| LAeq          | 1.02  | 0.47  | -1.39 E-04 | 0.94           | -0.15   | 0.14     | 0.22      |

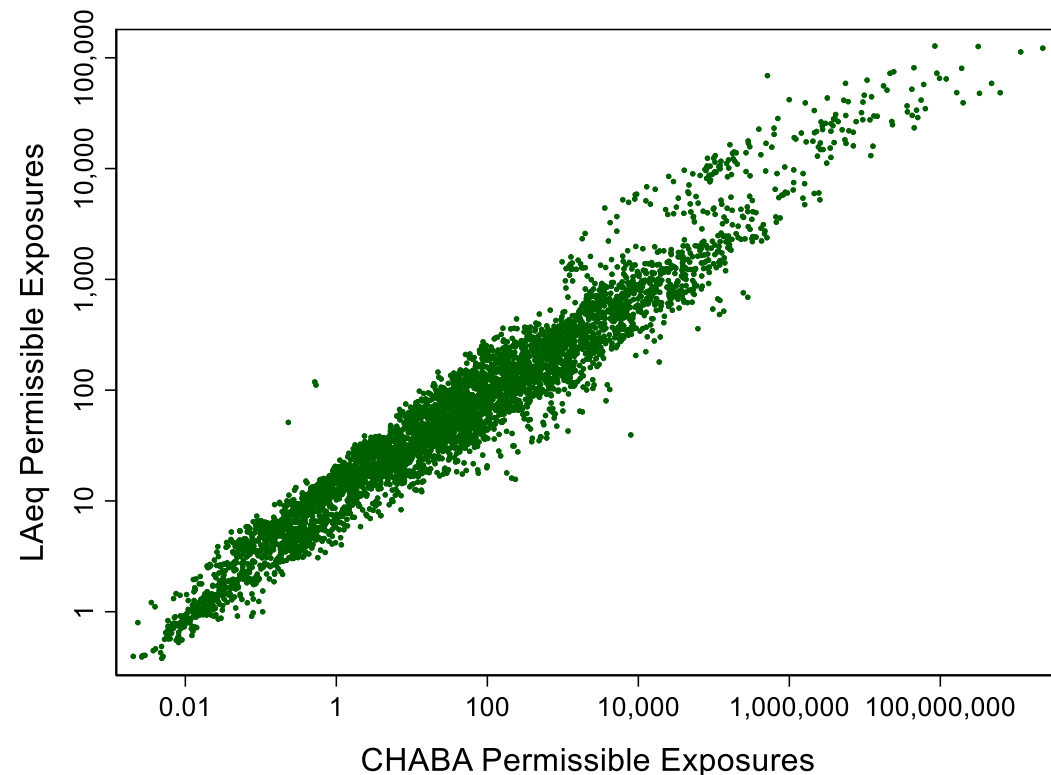

# What about longer A-durations?

- 75mm Pack Howitzer
- Blanks:
  - 75mm and 10 gauge
- Distances:
  - 1 to 24 meters
- Peak levels:
  - 142 to 174 dB SPL
- A-durations:
  - 0.25 to 4.7 ms

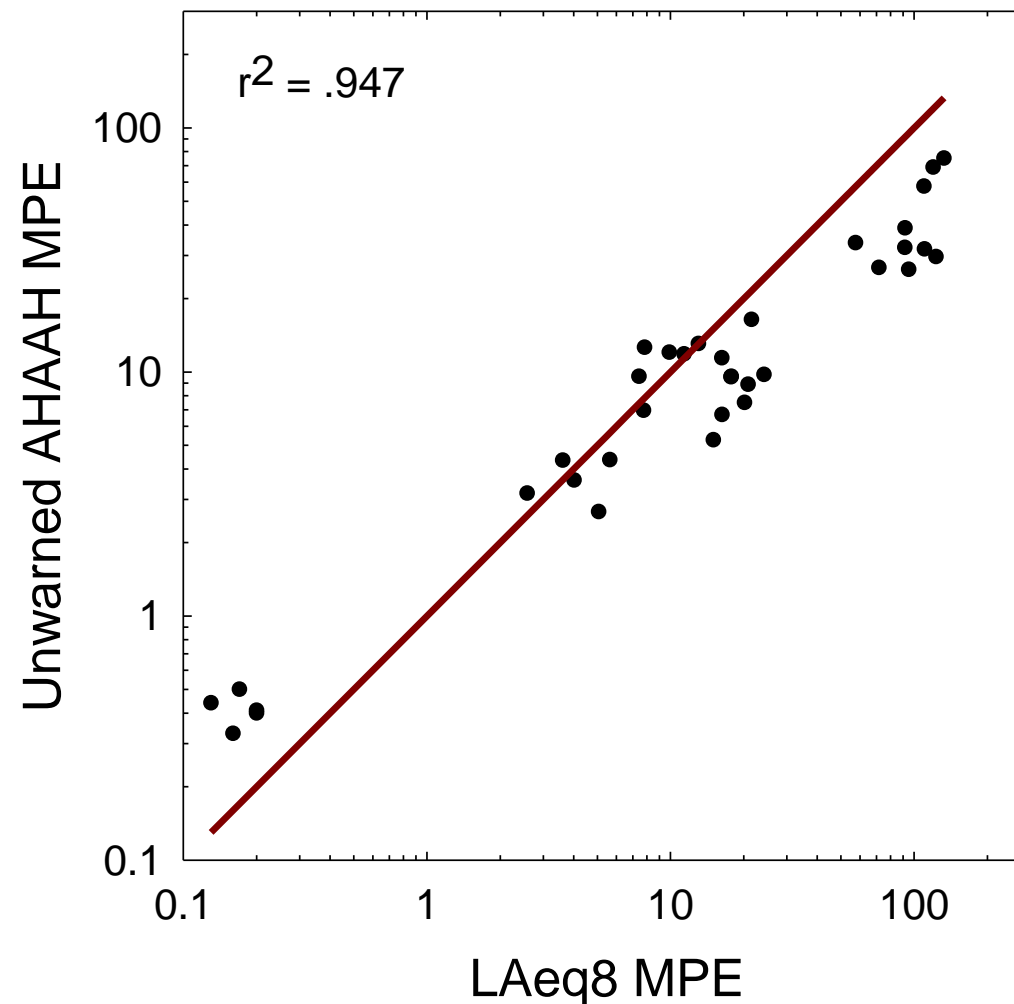

# What about protected waveforms?

- AR-15 (.223) rifle
- Peak levels:
  - 130, 150, 170 dB SPL
- Hearing Protectors
  - Bilsom 707 Impact II earmuff
  - Pod Express
  - Combat Arms version 4
  - BlastPLG EB1

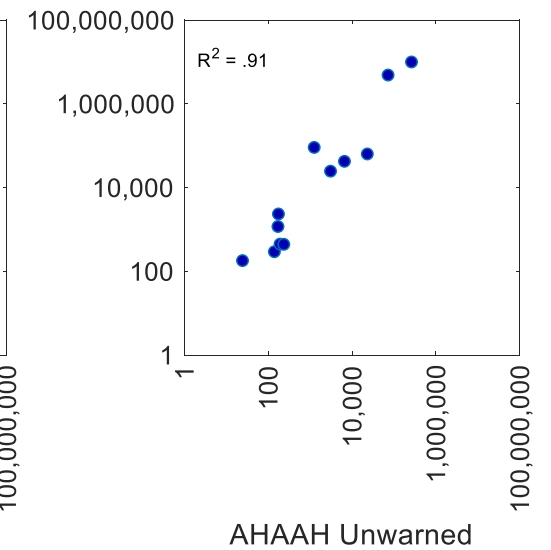
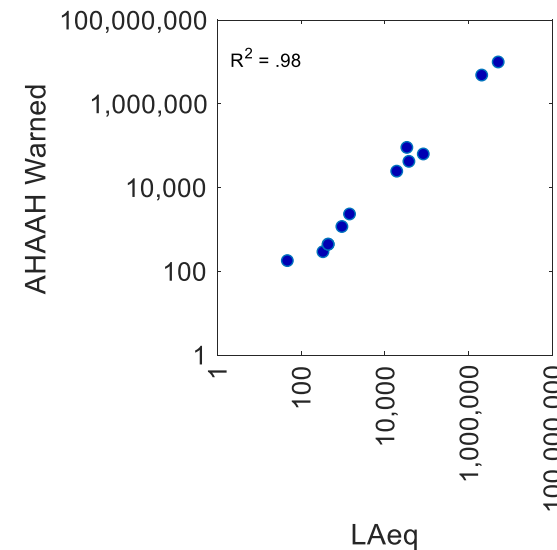
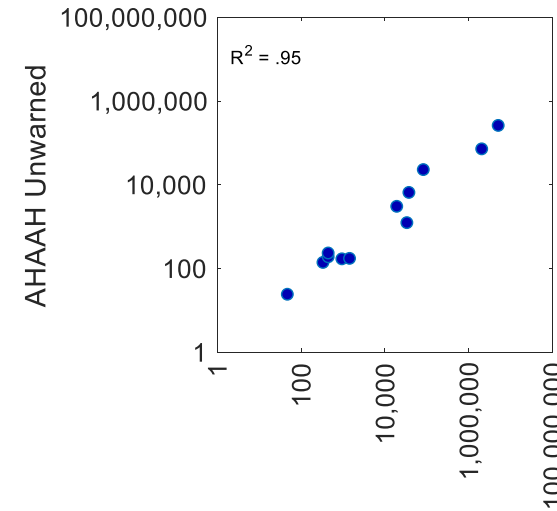

Data from Murphy et al., 2011

# What about suppressed weapons?

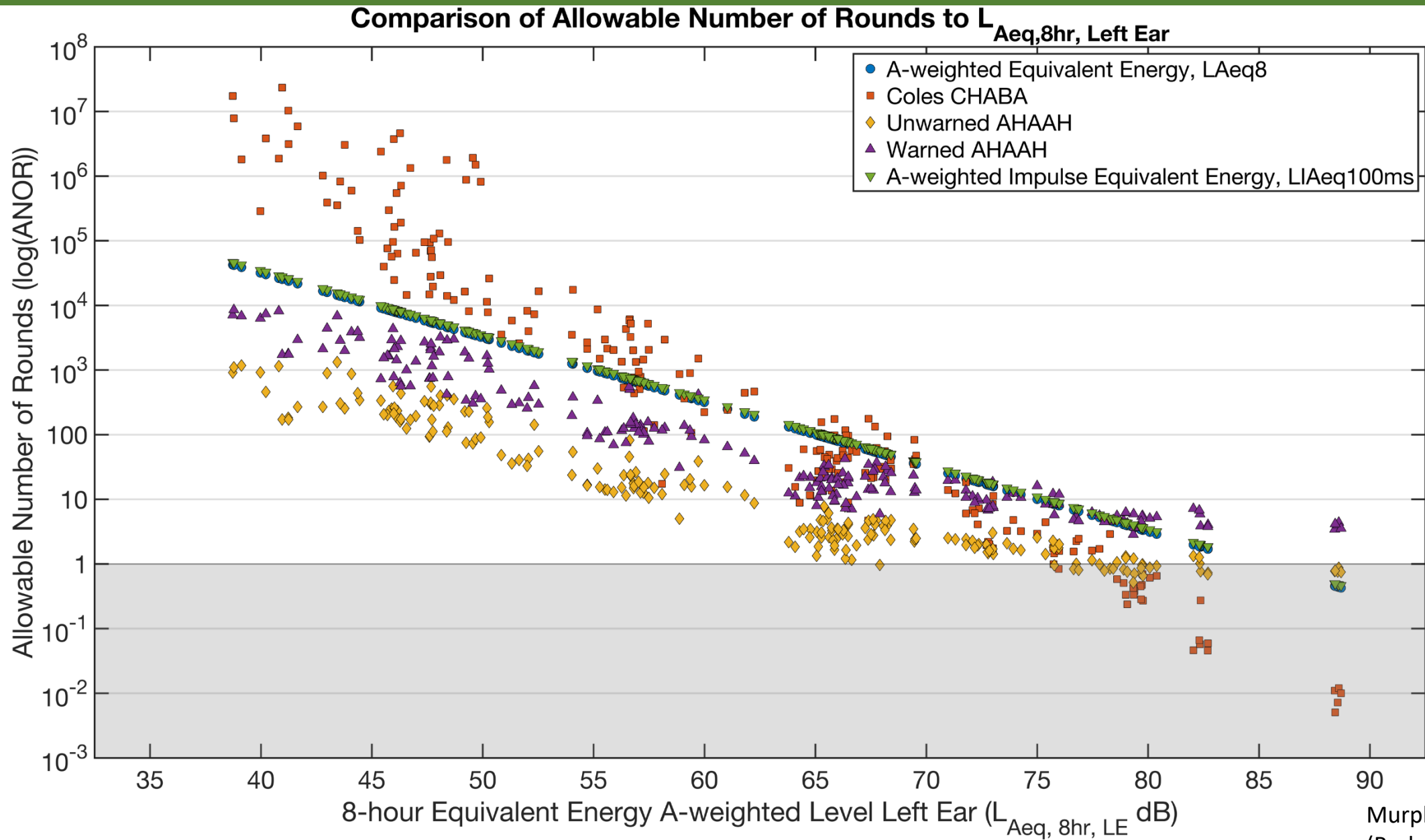

# What about suppressed weapons?

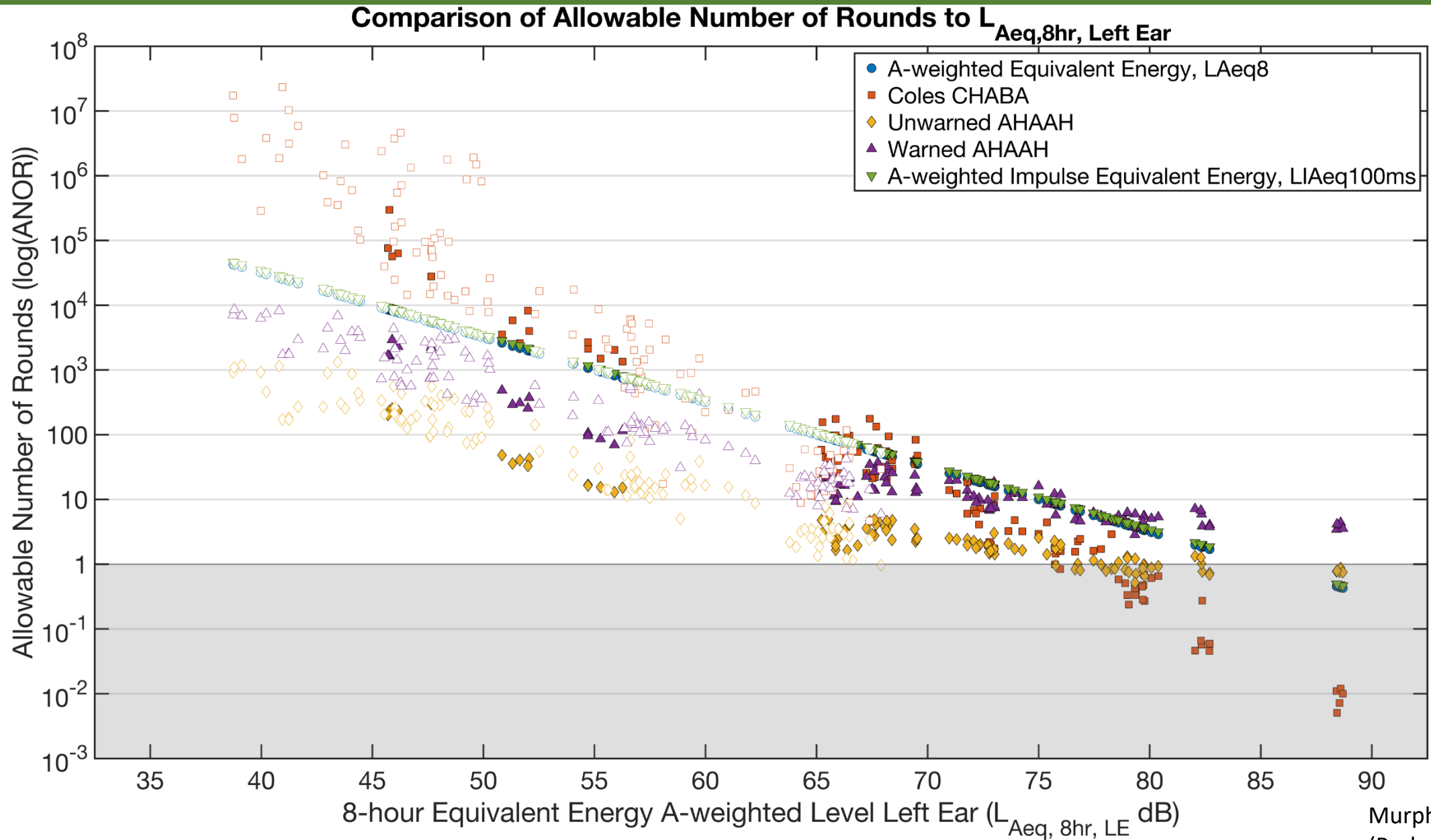

# What about reverberant environments?

- .22 Caliber revolver
- Hunting blind
  - 1.8 x 1.8 x 2 m
- 16 microphone locations
  - Grid layout

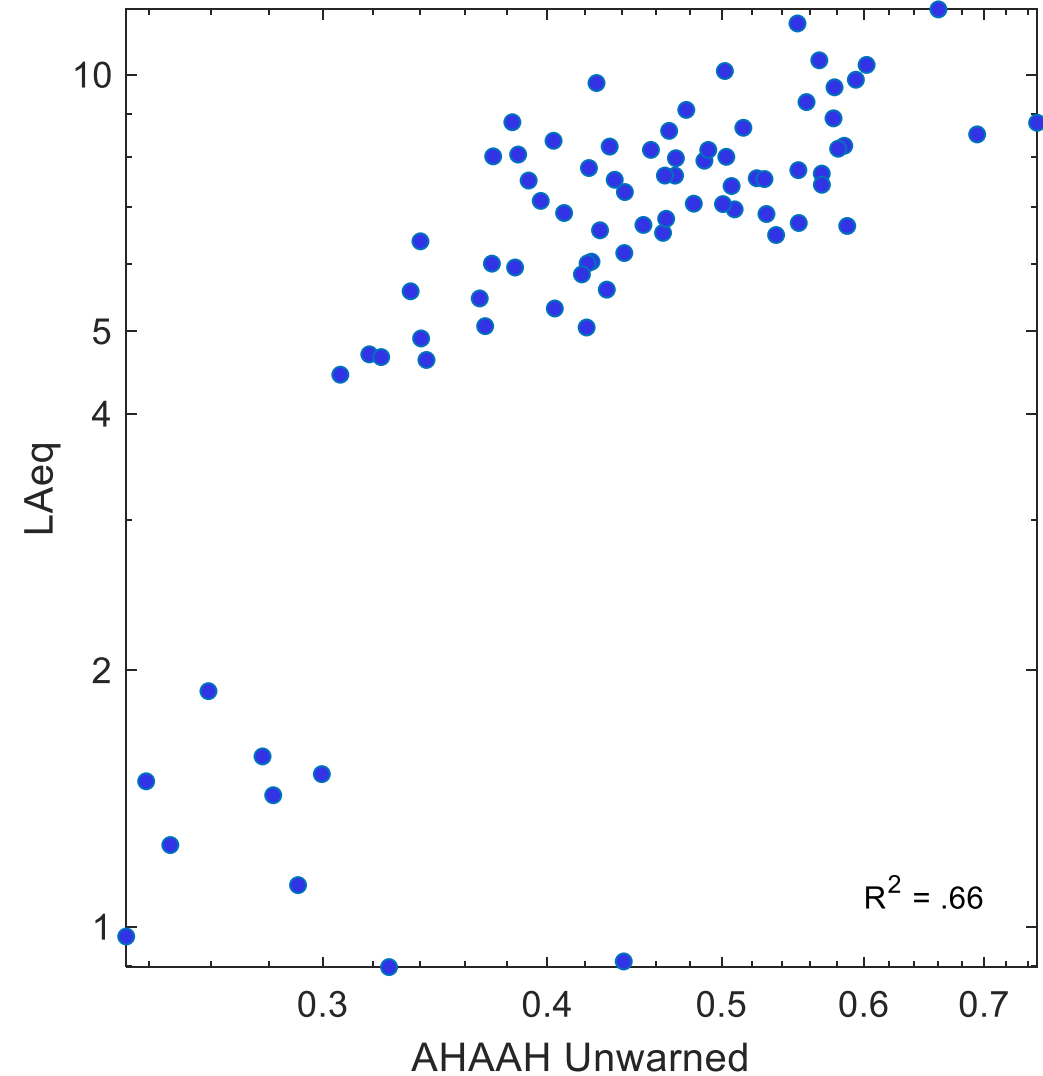

# The problem of predicting for individuals

- Chinchilla (N=905)
- 137 exposure conditions
  - Shock tube
  - Spark gap
  - Impact
  - Loudspeaker
- Number of exposures
  - 1 to 100
- Inter-stimulus intervals
  - 0 to 600 seconds

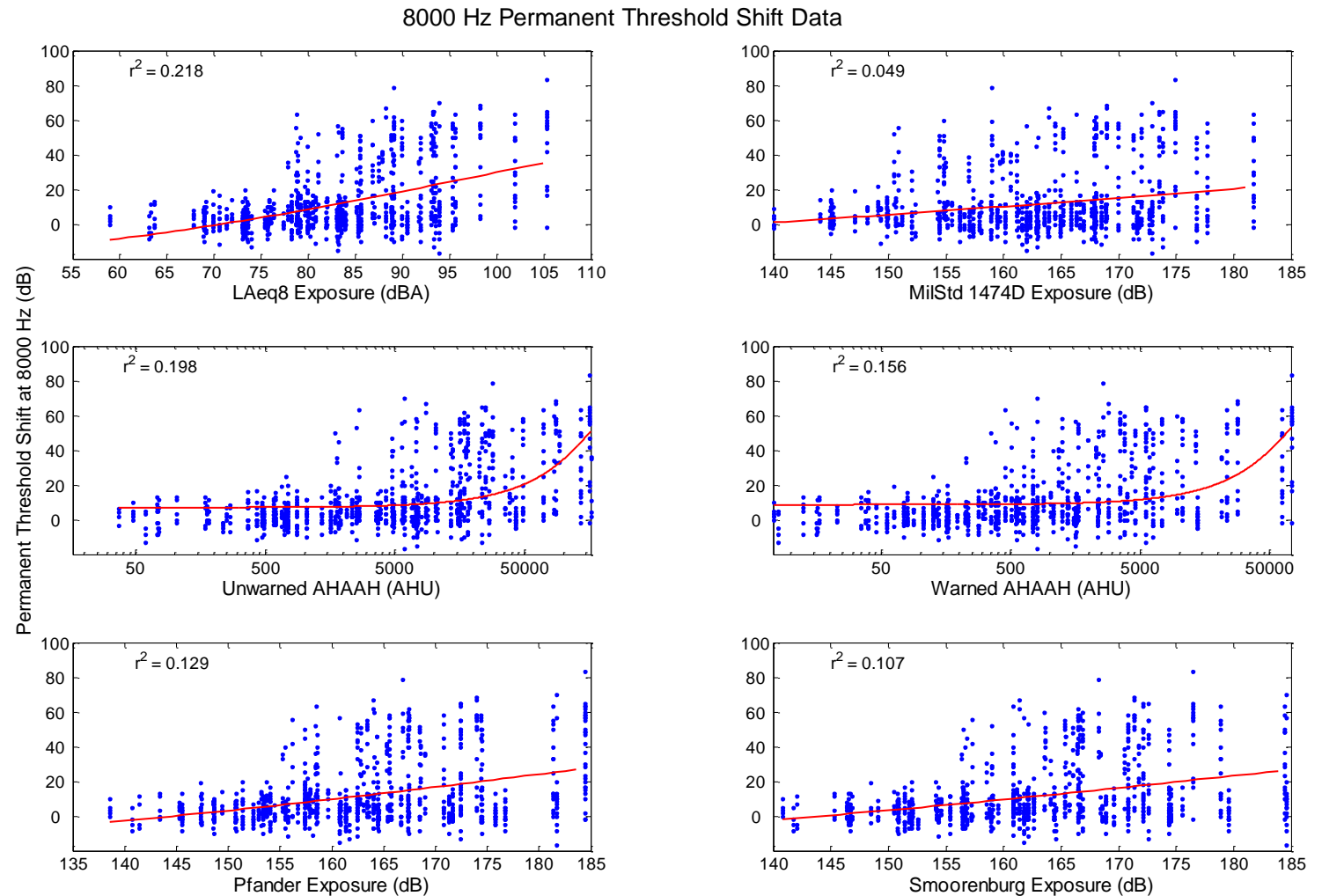

# Allowable Numbers of Rounds across DRCs

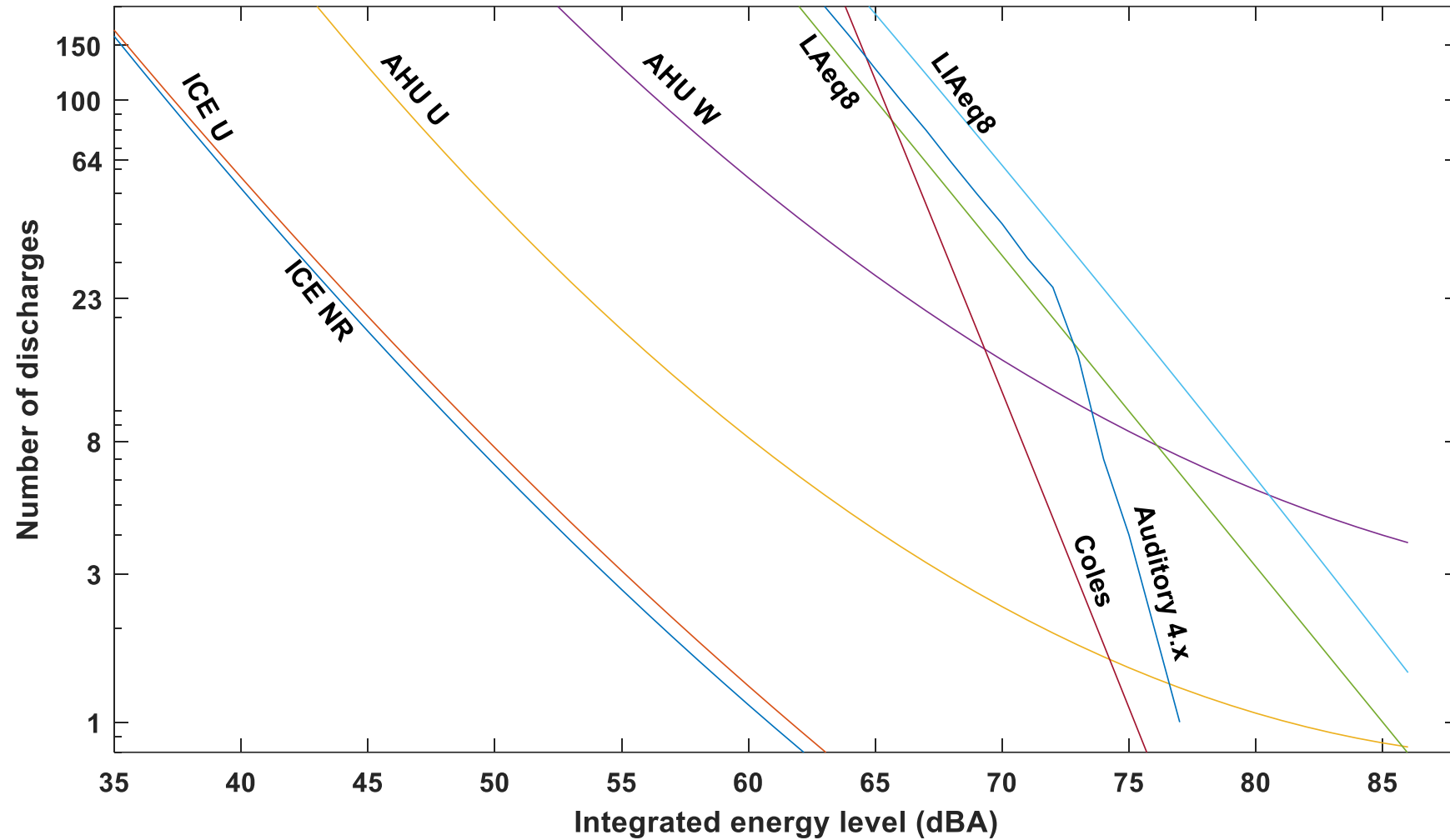

# Allowable Numbers of Rounds across DRCs - Testing

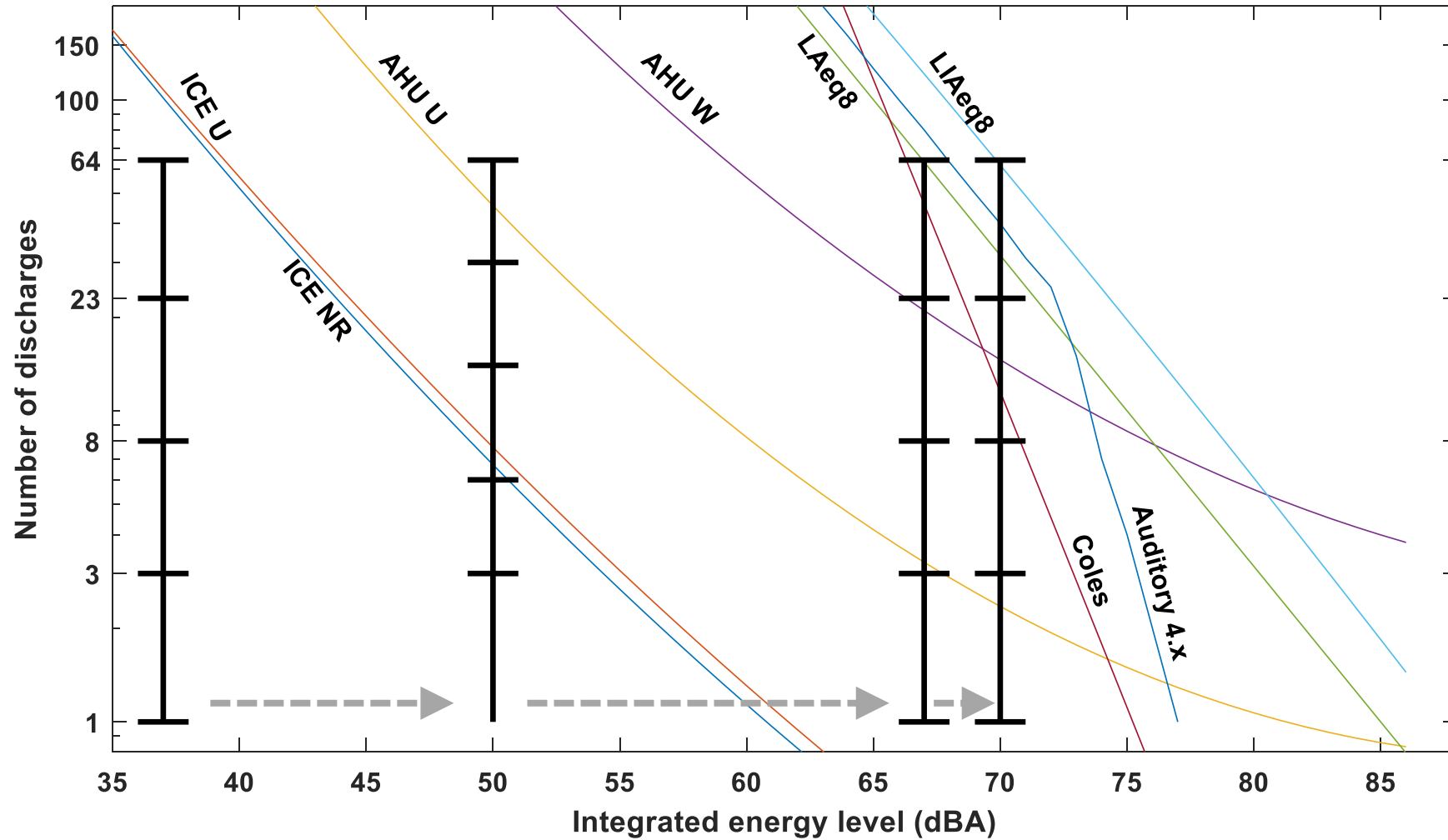

# Allowable Numbers of Rounds across DRCs - Testing

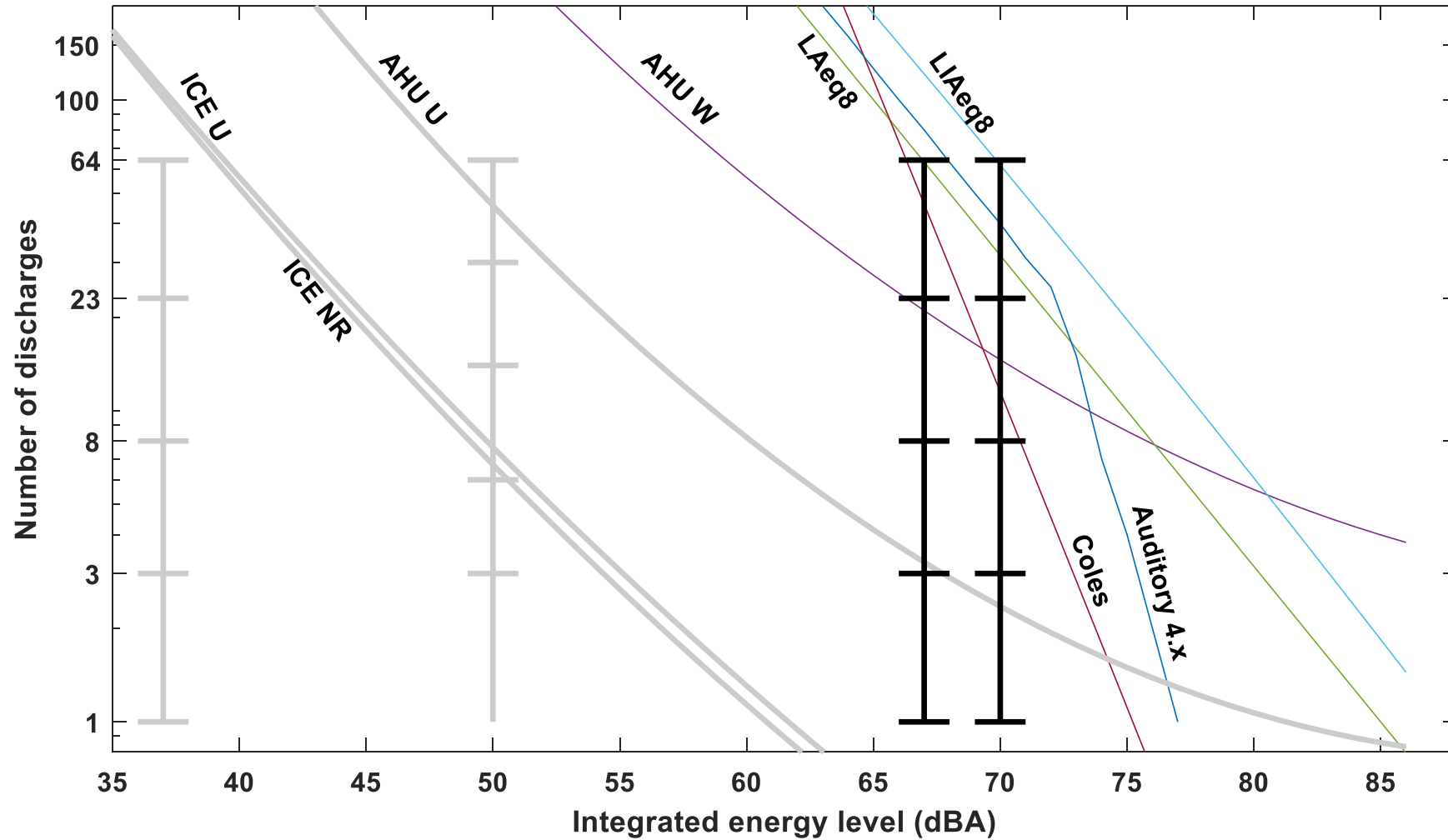

# Conclusions

Damage-risk criteria use the same information.

- Same construct, different indicators
- Vastly different limits
- High correlations and predictability

At most, one approach is correct.

- All have been developed using available data, which are limited.
- Informed selection can only occur through careful prospective study.

Inter-subject variability is largely unexplained.

Prospective empirical testing is complicated, but feasible.

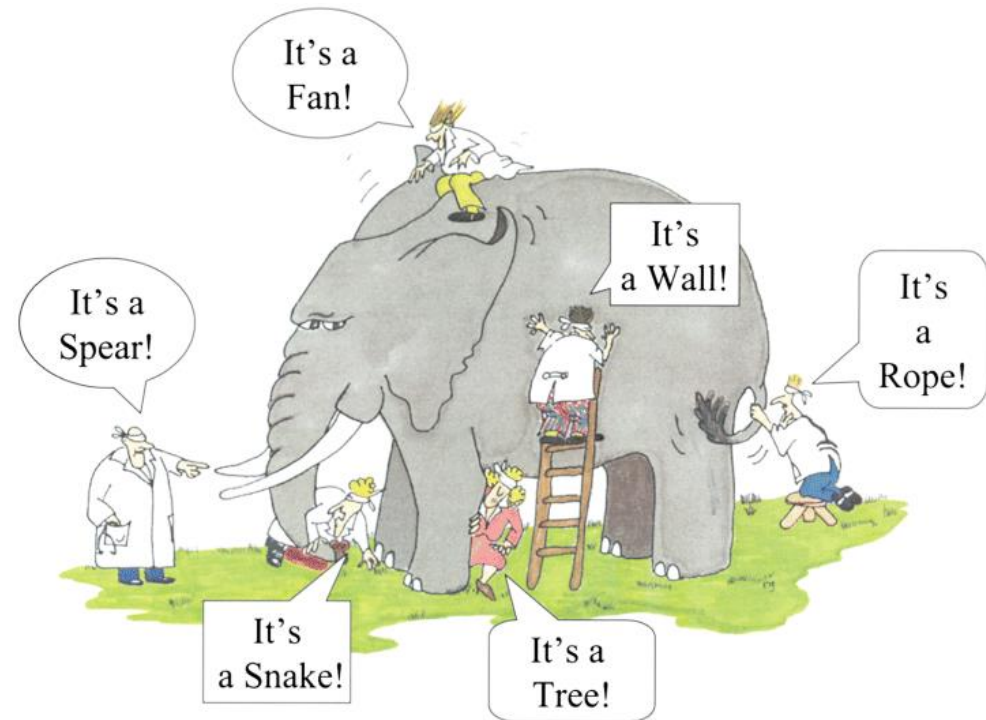



# Methods - Measurement

- 18 microphones, 1.5 m above ground
  - At shooter's left ear
  - 3 radial distances (1.5, 3 and 6 m)
  - Grazing incidence
- Instrumentation
  - National Instruments PXIe-4499
  - National Instruments PXI-4462
  - 1/8" and 1/4" microphones

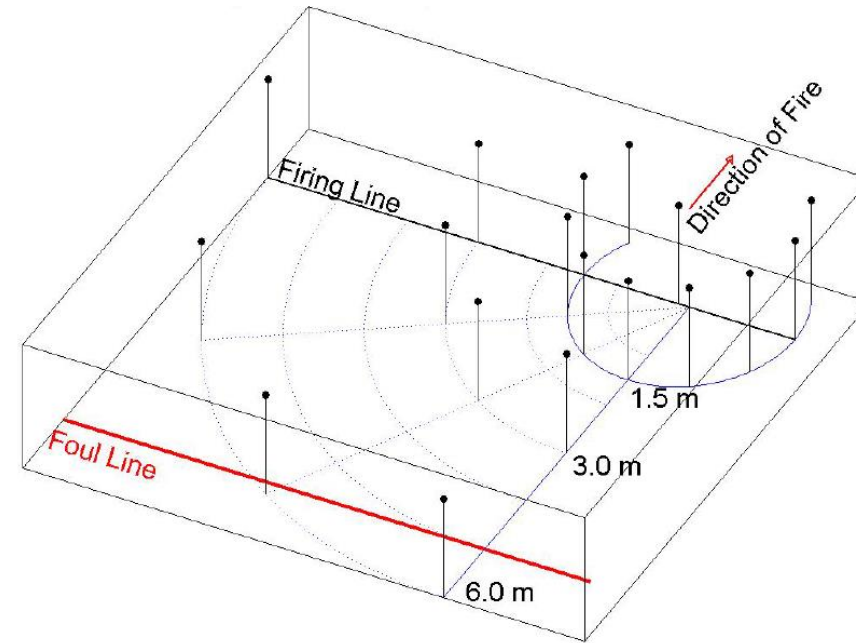

# Comparison of DRC reduction and Peak reduction

Comparison of the Reduction in Damage Risk Criterion  
MilStd 1474D,  $L_{Aeq8hr}$ ,  $\text{Log}_{10}(\text{ARU})$  with Peak Level Reduction

